

1 General Information

FP fan coil unit summarize FP fan coils series is suitably used for the central control a/c system, especially in the area with variable loads requirement. Due to its advanced design, good performance, a variety of specifications, FP fan coils series can meet different requirements and used in different places. It can be used in the hotels, apartment buildings, villas, office buildings and hospitals etc.

2 Symbol Explanation

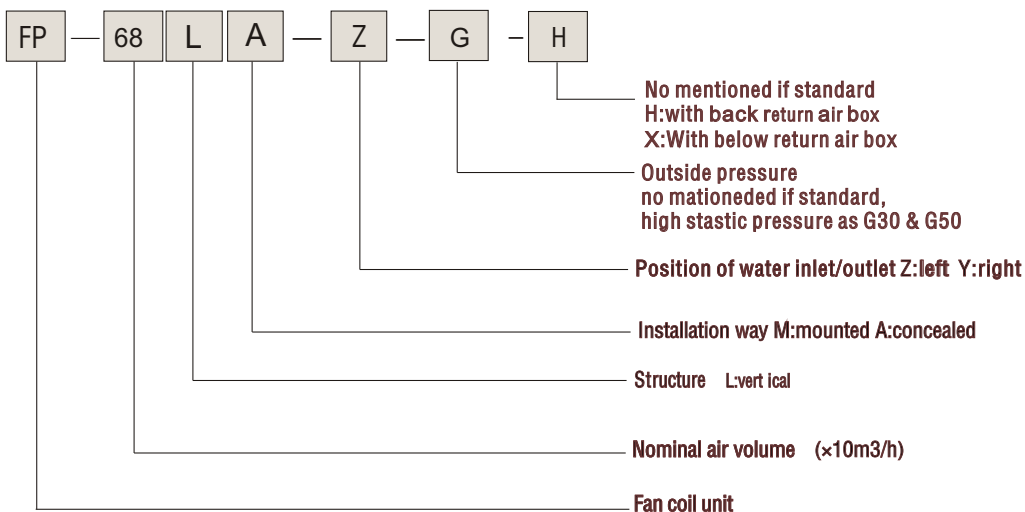

3 Characteristic

Vertical hidden
type FP-LA, LAP



- 1, Compact structure design, can be installed at the concave wall or under window dais, save space.
 - 2, supply air mode: front way (0°); Up way (90°); Diagonal way (45°)
 - 3, easy installation and maintain, low noise;
 - 4, can select high pressure such as LAG30 or LAG50;
- ★ The length of water tray pan can be added so as to the valve in the tray pan.
 - ★ The materials S.S. of the water tray pan can be selected;
- Note: the item with ★ should mentioned when order goods

4, Technical Specifications

Model		FP-34	FP-51	FP-68	FP-85	FP-102	FP-136	FP-170	FP-204	FP-238	
Air volume(m ³ /h)	H	340	510	680	850	1020	1360	1700	2040	2380	
	M	255	383	510	638	765	1020	1275	1530	1785	
	L	170	255	340	425	510	680	850	1020	1190	
Cooling capacity(W)	H	Total	1888	2795	3709	4625	5518	7046	8838	10578	12318
		Sensible	1310	1926	2528	3149	3722	4863	6073	7242	8389
	M	Total	1661	2432	3251	4030	4785	6182	7739	9158	10716
		Sensible	1099	1603	2133	2629	3148	4072	5082	6002	7040
	L	Total	1321	1933	2568	3182	3778	4900	6136	7281	8472
		Sensible	839	1231	1623	2005	2379	3120	3895	4609	5408
Heating capacity(W)	H	3143	4556	5997	7378	8707	11410	14254	16789	19476	
	M	2567	3732	4915	6054	7154	9395	11731	13845	16064	
	L	1879	2746	3622	4471	5295	6975	8713	10296	11953	
Noise(Db(A))		43	44	45	46	48	49	50	52	54	
Water flow(L/h)		302	454	605	756	907	1325	1545	1900	2200	
Cooling water resistance(KPa)		2.36	5051	10.43	19.06	25.25	8.53	13.41	20.72	29.86	
Heating water resistance(KPa)		1.79	4.19	7.93	10.07	19.20	6.49	10.20	15.75	22.70	
	Power	220V/1 Phase/50Hz									
	Qty.	1	1	1	1	1	2	2	2	2	
	Input power(W)	45	62	76	90	110	152	180	220	264	
	Output power(W)	16	16	20	30	40	30*2	40*2	50*2	60*2	
Fan	Type	Centrifugal									
	Qty.	1	2	2	2	2	2	2	2	2	
Cooler	Type	Copper pipe thrill through Aluminum fee, With manual release air valve									
	Rows&Distance	3 rows / 2.26mm distance									
	In/Out water pipe	Dia. Of In/Out water pipe & Condensate pipe is 3/4"									

- 1, The air volume is the standard unit tested when dry working condition;
- 2, The test conditions for rated cooling capacity of fan coil unit are: Dry bulb temperature is 27°C. Wet bulb temperature is 19.5°C. Water temperature entering the unit is 7°C. Temperature difference between inlet and outlet water is 5°C.
- 3, The test conditions for rated heating capacity of fan coil unit are: Dry bulb temperature is 21°C. Water temperature entering the unit is 60°C. Rated water volume same as for the cooling test
- 4, Low pressure unit is the pressure is 12Pa when the unit without outlet and filter, while the high pressure unit is the pressure is 30 or 50 Pa when the unit without outlet and filter.
- 5, Design and materials are subject to change without notice.

2-pipe cooling capacity technical parameter

3-rows inlet air temperature: DB27 °C/WB19.5 °C (Relative humidity 55%)

Model	Air flow L/h	Water resistance KPa	Inlet water temperature (°C)									
			5		6		7		8		9	
			Sensible	Total	Sensible	Total	Sensible	Total	Sensible	Total	Sensible	Total
FP-34	150	0.7	1193	1616	1159	1525	1125	1412	1092	1321	1058	1231
	250	1.7	1360	2024	1310	1947	1260	1775	1209	1639	1159	1525
	350	3.1	1478	2299	1428	2160	1344	1979	1293	1843	1243	1707
	450	4.8	1545	2432	1478	2296	1428	2160	1360	2001	1293	1843
FP-51	300	2.6	1877	2704	1829	2568	1755	2387	1683	2205	1634	2069
	400	4.4	2024	3022	1951	2840	1853	2659	1804	2477	1731	2296
	500	6.5	2146	3297	2048	3114	1951	2885	1853	2659	1780	2455
	600	9.0	2219	3480	2121	3251	2048	3068	1951	2840	1829	2591
FP-68	450	6.2	2592	3847	2496	3595	2400	3343	2304	3114	2208	2885
	550	8.8	2720	4167	2592	3847	2496	3617	2400	3343	2272	3068
	650	11.9	2816	4350	2720	4121	2592	3824	2464	3526	2368	3251
	750	15.3	2880	4534	2784	4259	2656	3984	2528	3709	2400	3389
FP-85	600	11.3	3228	4854	3149	4579	2992	4259	2874	3984	2756	3663
	700	15.0	3386	5174	3228	4854	3110	4488	2953	4167	2835	3847
	800	18.8	3464	5404	3307	5037	3189	4717	3031	4350	2913	4007
	900	23.2	3543	5541	3386	5220	3267	4900	3110	4534	2953	4121
FP-102	750	18.0	3908	5953	3722	5495	3583	5129	3443	4762	3303	4296
	850	22.5	4001	6182	3862	5770	3676	5358	3490	4946	3350	4579
	950	27.4	4094	6365	3908	5953	3769	5587	3583	5129	3396	4717
	1050	32.7	4187	6503	4001	6136	3862	5770	3676	5312	3490	4842
FP-136	900	4.3	4801	7006	4678	6594	4494	6136	4309	5724	4124	5266
	1100	6.1	5048	7602	4863	7098	4678	6594	4494	6136	4309	5678
	1300	8.2	5294	8059	5048	7556	4801	6960	4617	6502	4432	5953
	1500	10.6	5417	8334	5171	7876	4986	7372	4740	6754	4494	6228
FP-170	1200	8.6	6226	9250	5995	8701	5765	8105	5534	7510	5303	6960
	1400	11.3	6456	9800	6226	9187	5918	8518	5688	7922	5457	7281
	1600	14.3	6687	10257	6380	9617	6149	8975	5841	8243	5534	7602
	1800	17.6	6841	10578	6533	9937	6226	9250	5995	8609	5688	7876
FP-204	1500	13.6	7513	11265	7151	10441	6880	9708	6608	9021	6336	8288
	1700	17.0	7694	11631	7423	10990	7061	10120	6698	9387	6427	8655
	1900	20.8	7785	11998	7513	11311	7242	10578	6880	9708	6518	8930
	2100	24.8	7966	12364	7694	11631	7332	10899	7061	10120	6698	9204
FP-238	1800	20.9	8808	13280	8389	12364	8074	11494	7759	10670	7340	9800
	2000	25.2	9018	13692	8598	12868	8179	11906	7864	10990	7550	10120
	2200	29.8	9122	14013	8808	13188	8389	12318	7969	11357	7654	10441
	2400	34.8	9227	14379	8913	13463	8493	12593	8179	11723	7759	10670

Design and materials are subject to change without notice.

2-pipe heating capacity technical parameter

3-rows inlet air temperature: Db21 °C

Model	Air flow L/h	Water resistance KPa	Total heating capacity						
			Inlet air temperature °C						
			40	45	50	55	60	65	70
FP-34	150	0.5	1315	1670	2027	2387	2749	3112	3478
	250	1.3	1470	1863	2259	2657	3056	3457	3859
	350	2.3	1543	1955	2369	2784	3200	3618	4037
	450	3.6	1586	2009	2432	2857	3284	3711	4139
FP-51	300	2.0	2054	2604	3157	3713	4272	4832	5393
	400	3.3	2158	2735	3314	3896	4479	5064	5650
	500	5.0	2225	2818	3413	4010	4609	5209	5811
	600	6.9	2270	2875	3481	4089	4698	5309	5921
FP-68	450	4.7	2775	3516	4260	5007	5756	6507	7260
	550	6.7	2861	3624	4389	5157	5926	6698	7472
	650	9.0	2923	3701	4481	5264	6048	6834	7622
	750	11.6	2969	3758	4550	5344	6139	6936	7734
FP-85	600	8.6	3456	4377	5301	6229	7159	8091	9025
	700	11.3	3532	4472	5415	6361	7309	8260	9212
	800	14.3	3590	4545	5503	6463	7425	8389	9354
	900	17.6	3637	4603	5572	6543	7516	8491	9467
FP-102	750	13.7	4109	5203	6300	7401	8504	9610	10717
	850	17.1	4179	5290	6404	7522	8642	9764	10888
	950	20.8	4235	5360	6488	7619	8753	9888	11025
	1050	24.9	4281	5417	6557	7699	8843	9990	11137
FP-136	900	3.3	5200	6592	7992	9398	10810	12226	13646
	1100	4.7	5369	6804	8245	9692	11144	12601	14061
	1300	6.3	5492	6957	8428	9904	11385	12870	14358
	1500	8.1	5585	7073	8566	10064	11567	13073	14582
FP-170	1200	6.5	6646	8420	10201	11988	13782	15580	17382
	1400	8.6	6796	8608	10426	12250	14079	15913	17751
	1600	10.8	6913	8753	10600	12452	14309	16170	18034
	1800	13.4	7006	8870	10739	12613	14492	16375	18261
FP-204	1500	10.4	7867	9964	12070	14182	16300	18423	20551
	1700	12.9	8004	10136	12274	14420	16571	18727	20886
	1900	15.8	8116	10275	12441	14614	16791	18973	21159
	2100	18.8	8207	10389	12577	14771	16971	19174	21380
FP-238	1800	15.9	9185	11631	14084	16544	19011	21483	23959
	2000	19.1	9313	11790	14275	16766	19264	21766	24273
	2200	22.7	9419	11923	14434	16951	19474	22001	24533
	2400	26.4	9509	12035	14568	17107	19651	22200	24752

Note: Hot water temperature should not above 70 to avoise danger
Design and materials are subject to change without notice.

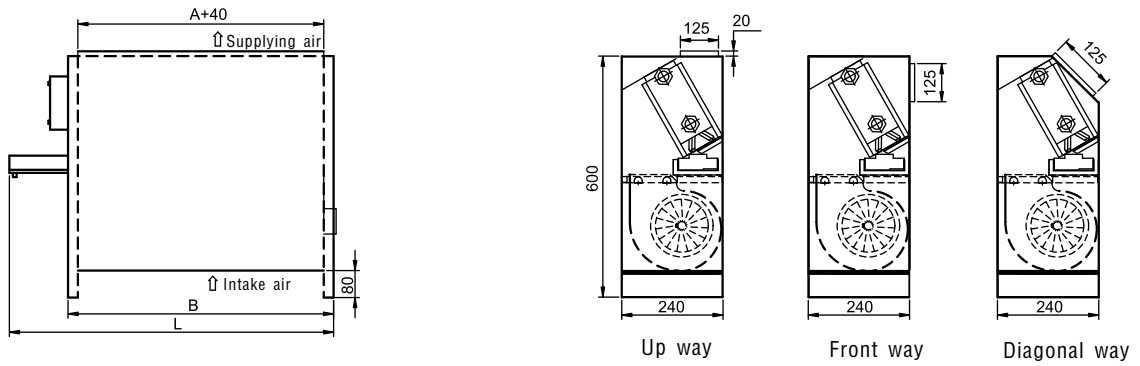

Specification Size	34	51	68	85	102	136	170	204	238
L	695	795	895	1020	1120	1520	1620	1820	2020
A	515	615	715	840	940	1340	1440	1640	1840
B	595	695	795	920	1020	1420	1520	1720	1920

5 Wiring Diagram

Wiring diagram for LA/LAP with wiring connection to 3-speed on-off switch

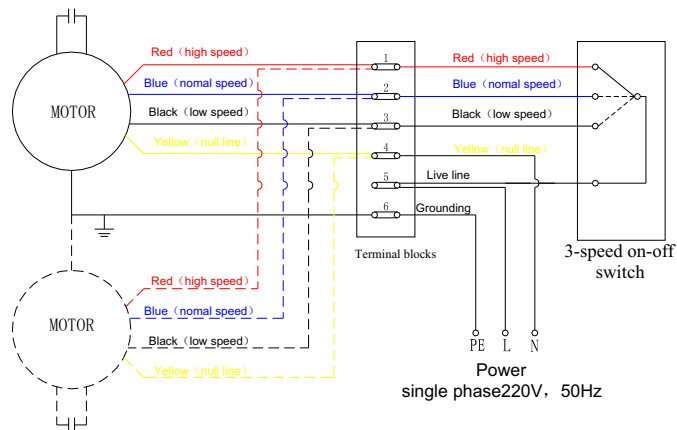

Note: The broken line part is applicable only to FP-136, FP-170, FP-204 and FP-238.

Wiring diagram for LA/LAP with DIRECT wiring connection to power supply

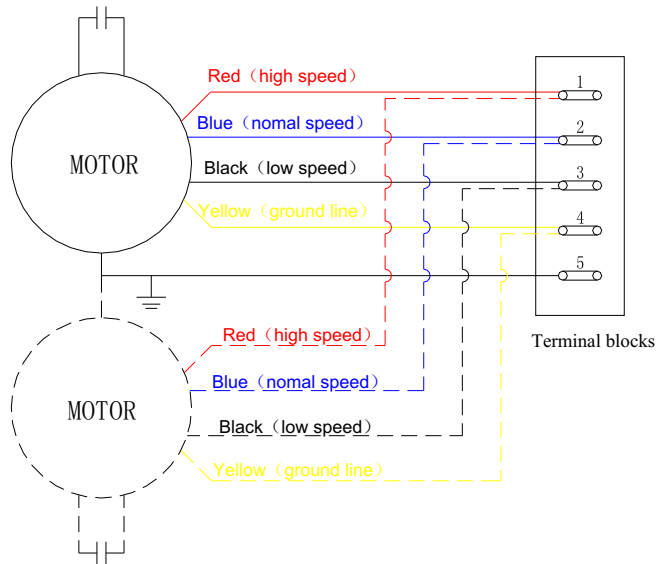

Note: The broken line part is applicable only to FP-136, FP-170,FP-204 and FP-238.

Wiring diagram for LA/LAP with wiring connection to temperature regulator controller

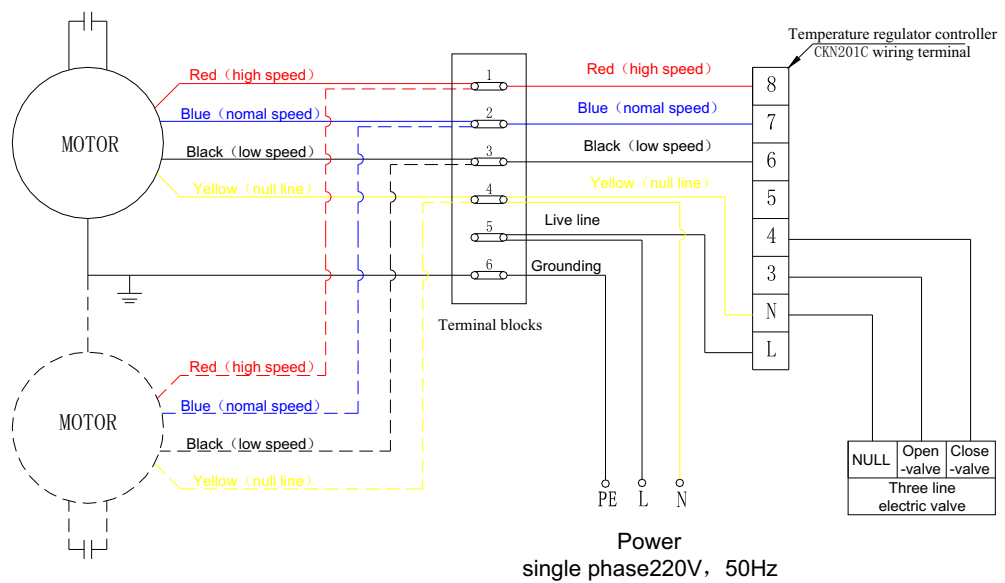

Note: The broken line part is applicable only to FP-136, FP-170,FP-204 and FP-238.

6 Illustration of Installation

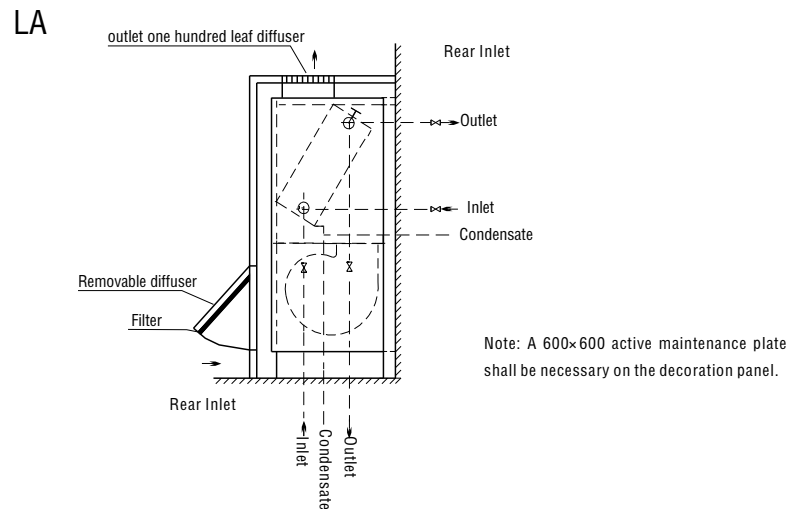

7 Installation







- 1, The outlet pipe is at the upper side of the heat exchanger while the inlet pipe is at the lower side. The condensed water outlet pipe is at the lowest point.
- 2, The unit shall be installed horizontally. And the installation of the condensed water pipe shall bear enough drop height to ensure the normal outlet of condensed water.
- 3, Valves shall be installed at the outside for in/out pipe for the adjustment of water flow and to cut off the water supply during maintenance.
- 4, Air duct and water pipe connected to the air condition units shall be supported separately from the units.
- 5, Necessary cleaning shall be applied to the system before water supply to ensure the exchange efficiency.
- 6, Before the initial start-up, check the wiring connections, grounding condition and if there are any remaining dirt. When everything is ready, start the fan and check the rotation direction.
- 7, Freeze-proofing measures shall be taken in pressure debug in winter,

8 Operation, Maintenance

- 1, Start the fan and pump, and the unit will run. Release the gas if necessary.
- 2, In idle time, the unit shall be filled with water to avoid erosion. In winter, certain anti-frost crack measures shall be applied.
- 3, In winter, the temperature of applying hot water shall be no less than 60°C; the supplying water shall be clean.
- 4, The air filter shall be cleaned or replaced periodically.
- 5, Apply full-range maintenance after running for two years. Use appropriate chemicals to clean the heat exchanger. The supplier may provide charged services.
- 6, Check the wiring connection, protection devices and the grounding to remove all potential dangers.

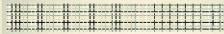
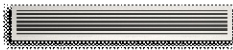
9 Product Order

- 1, Should mention the type, model, specification of the airflow and use the operation mode exhaustively while ordering.
- 2, Should mention the position of inlet water pipe, outlet water pipe and condensate pipe.
- 3, Some parts/devices/controller is included, but some are optional and need to order separately. Please refer to table below for details.
- 4, If there are special requirements/needs/demands, it should be mentioned in the contract.

Specs Name		Picture	WA	WAP	WAPF	LA	LAP	LM	WM	KM
			WAF	WHA	WHAF	WHAP	WHAPF	WOA	WOAP	
Switch	Simple On-Off 3-speed switch			○			○	●	○	○
	Temperature regulator controller			○			○	○	○	○
Outlet grille				○			○	●	●	●
Inlet grille				○			○	●	●	●
Fresh air inlet				○			○	○	○	—
Return Air Box				○			—	—	—	—
Filter				○			●	●	●	●
Condensate tray	Extending type			○			○	—	—	—
	Stainless steel			○			○	○	○	○
Flexible hose	Copper			○			○	○	○	○
	Stainless steel			○			○	○	○	○

Note: in the table

- “ ● ” mean it is INCLUDED and it is attached to the product itself.
- “ ○ ” mean it is NOT INCLUDED and it is optional, if needed have to order separately.
- “ — ” mean it is NOT APPLICABLE.